

## AMHS sorting options



P.V. Supa AMHS system can sort books and other material to different types of containers. These are a normal Sorting Bin, Ergo Trolley or an Index Tote system. Sorting bin is the most commonly used sorting unit that is easy to use with all kind of material. Ergo trolleys are best when used with material that has a fast circulation time. Index Tote with its totes/crates is the best solution for material that is to be transferred to another library.

### SORTING BIN

The Sorting bin can carry about 200 items at once (size of the item is 16x21x2,5cm). The capacity varies depending on the size of the material. If the AMHS system is 3-way sorting and the return frequency is about 600 items per hour, then the changing frequency for the bins is roughly one hour. Sorting bins can be changed without stopping the machine. When there is no sorting bin in a sorting position, the material that is supposed to go to the bin will be diverted to the overflow bin. Sorting bins can be used with all kinds of material.

› Ergonomic

› Easy to use

› Agile

**SORTING BIN**

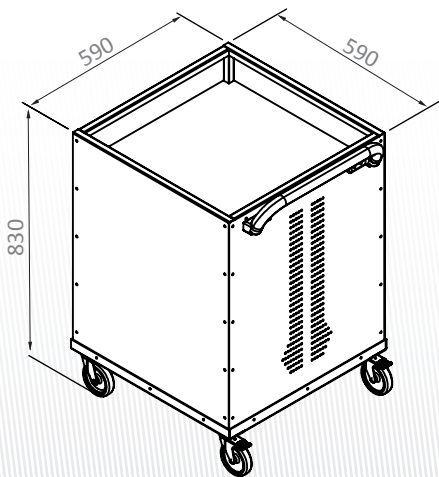

**ERGO TROLLEY**

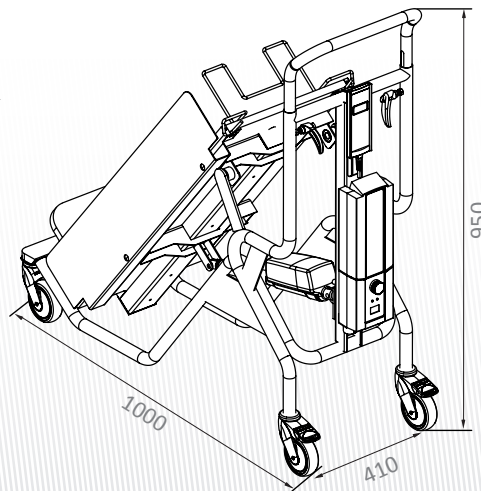

**INDEX TOTE**

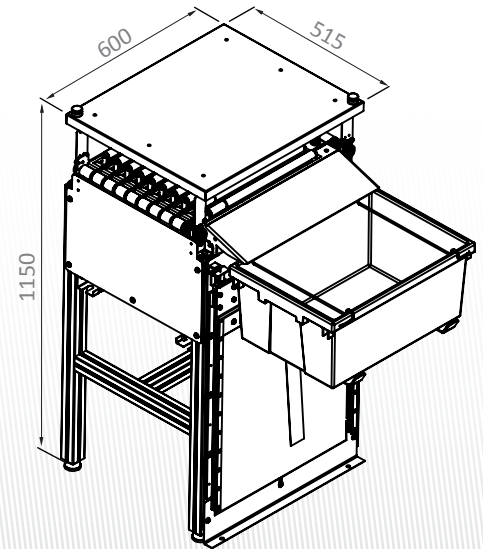

## ERGO TROLLEY

The capacity of an Ergo trolley is 30-60 items depending on the thickness of the items. Ergo trolleys can be changed without stopping the AMHS system. While changing, the material designated for the Ergo trolley is diverted to the overflow bin. The loading shelf of the Ergo trolley goes up and down electrically, helping to maintain working conditions ergonomical and convenient. Ergo trolley even looks nice enough to leave in the library for patrons to see, as the backs of the items come upwards making it easy to find items that have just been checked in. Ergo trolley is best suited for handling of books.

### SORTING BIN:

- › Lockable wheels
- › Spring loaded bottom with bearings
- › Large capacity
- › Easy to move
- › Color: Can be chosen from RAL-colors
- › Dimensions (WxLxH)  
590 x 590 x 830mm
- › Inside hight of the box with the bottom down 450 mm
- › Certificates:

### ERGO TROLLEY:

- › Lockable wheels
- › Dimensions(LxWxH)  
1000 x 410 x 950mm
- › Returnsurface size (WxL)  
390 x 850 mm
- › Color: Can be chosen from RAL-colors
- › Certificates:

## INDEX TOTE

Index tote is a small lift for a Sorting module. It is used to fill transportation crates used by a library. The automation implemented in the Index tote helps library staff in handling the crates. Normally an Index tote can stack three crates on top of each other next to the sorting module from where they are easy to move aside to wait for transportation. This system improves the logistics between libraries as the library staff does not need to touch the material at all. Index tote with its crates is fit for all kind material.

### INDEX TOTE:

- › Index tote can be used with a variety of crates
- › The crates can be removed from Index tote by Tote Lifter, hand truck or other similar equipment similar equipment
- › Color: can be chosen from RAL-colors
- › Certificates:

### P.V. SUPA OY LTD

Muonamiehentie 14  
00390 Helsinki, FINLAND

Tel. +358 207 414 800  
Fax +358 207 414 801

sales@pv-supu.com  
www.pv-supu.com