

## EM 700 Security Gates

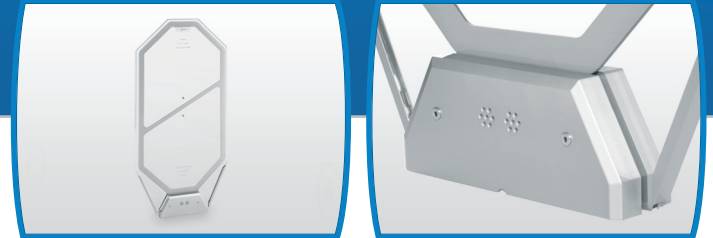

### TRANSPARENT ALARM SYSTEM FOR SMALL LABELS

The EM 700 security gates offered by P.V. Supa work with electromagnetic (EM) technology and EM labels. Since EM labels are thin, the EM 700 is perfect for bookshops and libraries. In addition, because the EM labels can be deactivated and reactivated multiple times, they are ideal for environments where the same item is being regularly scanned in and out, such as a library.

The EM 700 is a slim antenna in clear plexiglass. The transparent material creates a sense of space, invaluable for congested entrances. This kind of design is very popular among architects.

Alarm will be caused when someone tries to carry an article that contains activated EM alarm, through the gates. Items that have already been checked out, and where the EM alarm has been deactivated, won't cause an alarm on the gates. The alarm is notified by sound

and by light which is built into each antenna. There are several different types of alarm sounds and the length of the alarm sound and light is also adjustable.

The identification field, fluctuating 20 times in a second, identifies even EM labels hidden inside aluminum foil. Modern interference removal prevents false alarms, for example from wheelchairs, mobile phones or eyeglasses. The threshold value for alarm is adjustable according to the material used in a library. Because of this it is possible to achieve 100% identification without false positives.

EM security gates have a separate control unit that can control three gate antennas at the same time. It is possible to connect several control units together covering wide entrances. Gates can also be connected to video surveillance and other external systems.

› Attractive plexiglass design that creates a sense of space

› Reliable protection

› Perfect for libraries, video stores and shops with a broad selection of products

› Uses small, thin labels that can be deactivated and reactivated

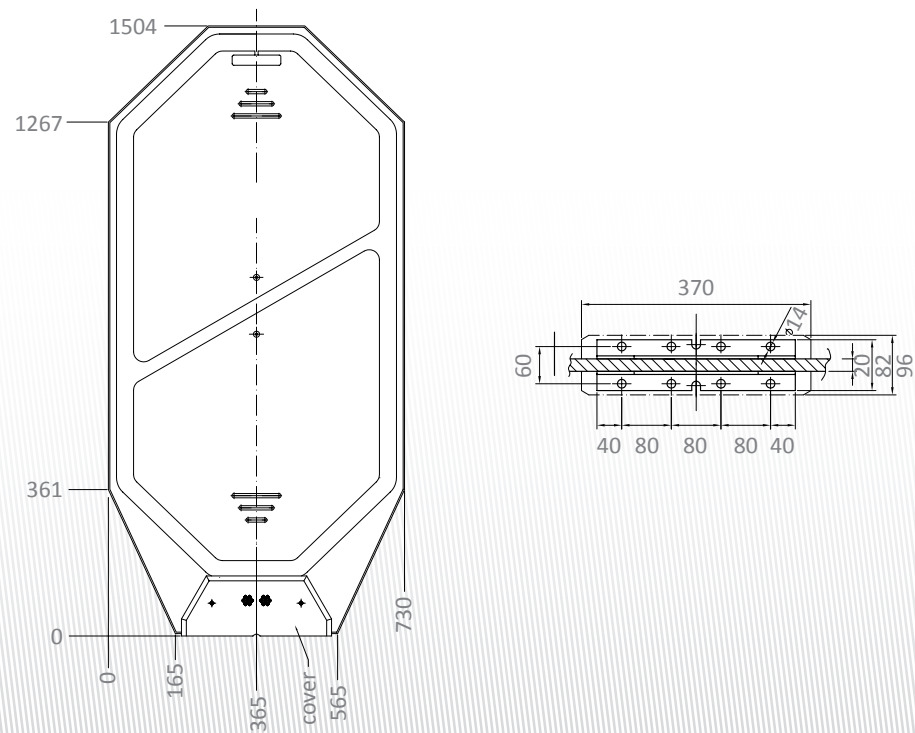
**GENERAL:**

- › Functions: Security, alarm by light and sound (type and volume adjustable)
- › Security: EM labes
- › Areas of application: Libraries, bookshops, multimedia stores
- › Options: patron counter

**COMPATIBILITY:**

- › EM alarm types: 3M, Colinear, Sensormatic, Knogo, 2M, TagIt
- › Excellent tolerance for interference

**TECHNICAL INFORMATION:**

- › 1-2 entrances with one control unit
- › Maximum width for one entrance: 1.2 m (alarm strip 8.8 cm)
- › Frequency: 488 Hz
- › Connections: third party systems i.e. video surveillance systems
- › Dimensions: (L x W x H) 730 x 96 x 1506 mm
- › Certificates: **CE FC**

**P.V. SUPA OY LTD**

Muonamiehentie 14  
00390 Helsinki, FINLAND

Tel. +358 207 414 800  
Fax +358 207 414 801

sales@pv-supu.com  
www.pv-supu.com